



VIVAT

Universal Innovation







VIVAT
Universal Innovation



Introduction of Sepahan Battery Industrial Complex



Sepahan Battery Industrial Complex was founded in 1999 as the most hi-tech enterprise in automotive battery manufacturing in Iran. It is occupying a total land area of 65,000 m². In the recent years, the complex has increased its production capacity to 5 million batteries / year and by implementing various development projects providing over 2,000 job opportunities. The manufacturing equipment are mostly fully automated and are made by the most renowned European battery manufacturing equipment suppliers such as Digatron, Sovema, TBS, BM, La Pneumatica, etc. Usage of state-of-the-art equipment and first-class raw material has enabled SBIC to produce the highest quality lead acid batteries for automotive applications to European, Japanese North American standards. Over the last 20 years, highly skilled engineers at SBIC have developed technical capabilities to be able to design and manufacture all types of batteries for OEM and after-market applications. SBIC's new products include EFB batteries for cars equipped with start-stop system and also UPS and solar batteries. Sepahan Battery also exports its products to the GCC, CIS countries and also to some of the African and European ones. Sepahan Battery Industrial Complex is the most advanced battery manufacturer in Iran because of the outstanding specifications as follows:

- 1- Self-sufficiency in battery production and making almost all of the raw materials and components used in its production.
- 2- Benefiting from information technology and implementing and executing fully developed information system and enterprise resource planning (ERP).
- 3- Manufacturing and supply of up-to-date products to the market using just-in-time (JIT) system, ensuring on-time delivery, increased working life, which leads to improved battery performance when being sold in the market and in order to benefits battery dealers and end users.
- 4- Creating suitable infrastructures to complete the cycle of production and recycling batteries to prevent environmental pollution and toxic contamination as one of the main values of the complex.



VIVAT
Universal Innovation



Start-Stop Automobiles

Due to the importance of environment issues and global warming in recent years, most car manufacturers have adopted various methods to decrease fuel consumption and emission of carbon dioxide. Since there are still problems for major electric or hybrid vehicles to enter in the global car market, simpler methods such as using the start-stop function (turning off the engine when stopping the car and turning it on again by releasing brake) have been considered in cars under the name of micro-hybrid and has spread rapidly. In some of these vehicles, this may be combined with other features such as regenerative braking.

Start-Stop technology can reduce fuel consumption in urban driving by 4 to 10 percent or more. CO₂ emission can be decreased by an average of about 5% using Start-Stop technology. With the addition of the brake energy recovery system to the micro-hybrid vehicle, the CO₂ emission will be reduced to 12%.

When the car's Start-Stop system is on, the engine shuts off when the speed is reduced to below 8 km/h. When the car is about to move forward, the system automatically turns on the engine when the driver releases the brake. The battery function in a micro-hybrid vehicle is much more difficult than the usual power supply function in a conventional vehicle (SLI function).



VIVAT
Universal Innovation



The difference between car battery performances with start-stop technology compared to conventional car batteries is summarized in the table below:

Start-Stop system	Conventional system
The battery is under a lot of pressure	The battery is under less pressure
In an environment suitable for start-stop system, such as city driving, the car may stop and restart in each kilometer (average 17,500 starts per year)	Number of car start times is less and usually 2 or 3 times a day (average 730 starts per year)
Short time periods between starts do not fully charge the battery.	During the trip, the battery is recharged using an alternator to compensate for the capacity used to start the car.
It is necessary for the battery to be able to go through continuous cycles and operate in the state of incomplete charge.	It is necessary for the battery to operate in the charge state (SOC) close to full charge.
It is necessary for the battery to be charged quickly in the intervals between the engine shutdowns and to provide the necessary power to operate the vehicle accessories when the engine is off.	The battery does not cycle continuously and is recharging at a lower speed.





EFB Battery

EFB (Enhanced Flooded Battery) is the most advanced type of liquid electrolyte batteries, which with the expansion of the use of start-stop technology in the world, contributes as a solution to reduce fuel consumption and also emissions of Carbon Dioxide and therefore is designed to meet the needs of this type of vehicles. These batteries are designed to meet the needs of vehicles equipped with start-stop performance by significantly extending their lifespan and improving dynamic chargeability to adapt to perform at high rate partial state of charge. In addition, due to its longer life than standard batteries, EFB is also suitable for conventional vehicles with high electrical consumption and also vehicles that require high number of starting times during the day.

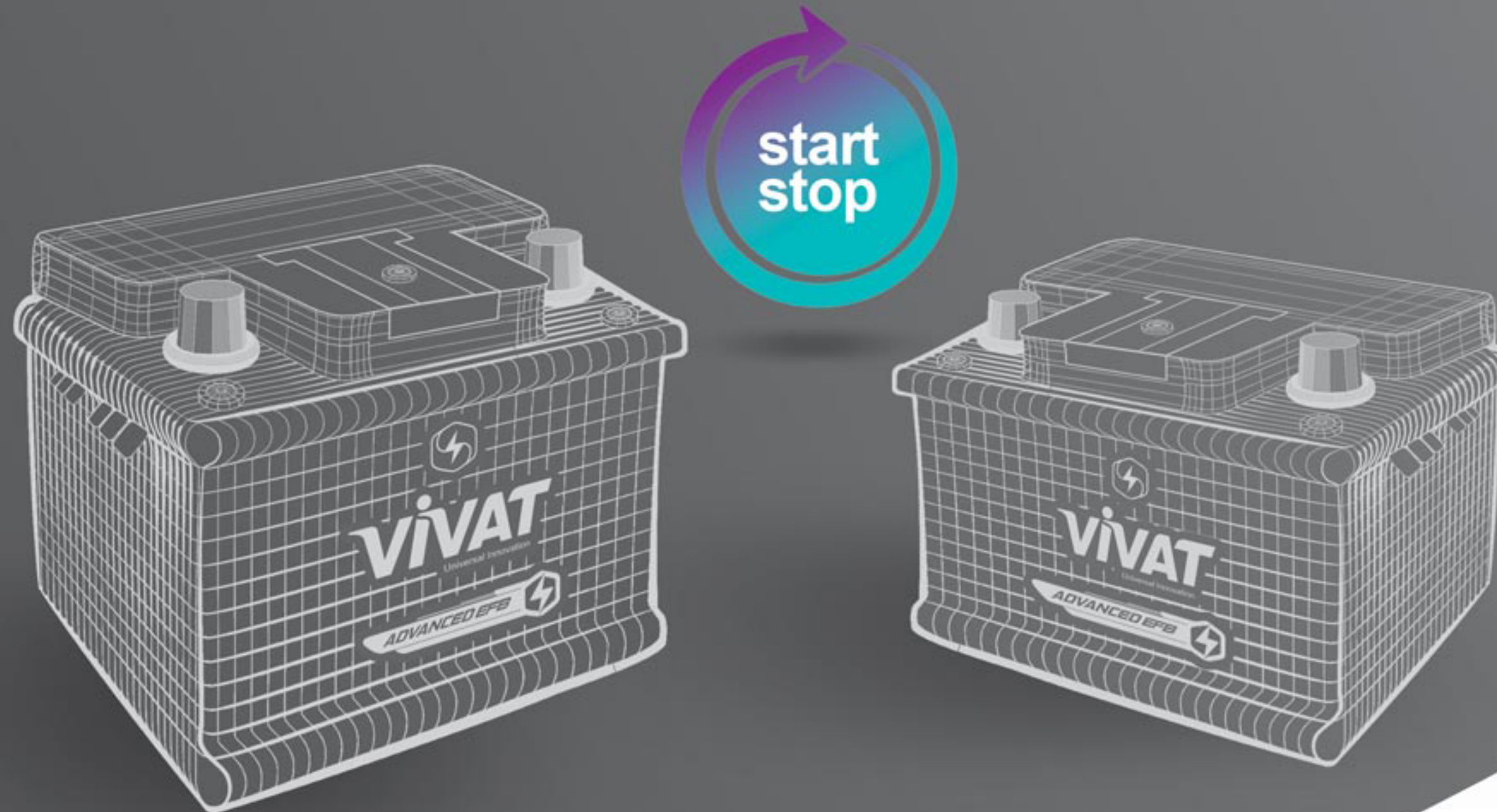





Vivat EFB Battery Specifications

1- Using punched grids produced with state-of-the-art technology with the following advantages:

- A) Increasing grid corrosion resistance
- B) Reducing grid growth by using full-frame grids
- C) Reducing the possibility of short circuit and separator rupture
- D) Reducing water consumption by using improved alloy

2- Using positive and negative paste with improved formula and structure with the following advantages:

- A) Increasing dynamic chargeability: high charging speed
- B) Prevent sulfatation of negative plates when performing in PSOC mode
- C) Increasing the cyclic life of battery by improving the positive paste structure
- D) Improving battery performance at high discharge depths



Vivat EFB Battery Advantages

- . Designed to be used in vehicles with start-stop function.
- . Can be used for all common vehicles with additional equipment and consumer devices.
- . High startup power and capable of a large number of starts during each trip.
- . Longer life than regular batteries (at least 2 times).
- . Less internal resistance than conventional batteries.
- . Ability to operate in partial state of charge(PSOC) condition.



New Technology



Full Frame Grid



Higher Cold Cranking Power



Start - Stop Ready



Passenger Car



2x Cycle Life



Rapid Charge Acceptance



Minimum Self Discharge



DIN

TYPE		Capacity 20 HR (AH)	Reserve Capacity (min)	CCA (EN/SAE) (A)	Max.Overall Dimension (mm)			Base Hold Down	Terminal Type	Terminal Layout
Box	Part Number				Length	Width	Total Height			
L1	EFB.SMF55087	50	75	520	207	175	190	B3	A1	0
L2	EFB.SMF55088	50	75	520	242	175	190	B3	A1	0
L2	EFB.SMF56020	60	94	600	242	175	190	B3	A1	0
L3	EFB.SMF57031	70	114	690	278	175	190	B3	A1	0

JIS

TYPE		Capacity 20 HR (AH)	Reserve Capacity (min)	CCA (EN/SAE) (A)	Max.Overall Dimension (mm)			Base Hold Down	Terminal Type	Terminal Layout
Box	Part Number				Length	Width	Total Height			
D23	EFB.SMF58D23L	60	94	580	238	178	225	B4	A1	0
D23	EFB.SMF58D23R	60	94	580	238	178	225	B4	A1	1

JIS

TYPE		Capacity 20 HR (AH)	Reserve Capacity (min)	CCA (EN/SAE) (A)	Max.Overall Dimension (mm)			Base Hold Down	Terminal Type	Terminal Layout
Box	Part Number				Length	Width	Total Height			
D26	EFB.SMF68D26L	70	114	680	257	176	225	B4	A1	0
D26	EFB.SMF68D26R	70	114	680	257	176	225	B4	A1	1
D26	EFB.SMF78D26L	80	134	780	257	176	225	B4	A1	0
D26	EFB.SMF78D26R	80	134	780	257	176	225	B4	A1	1

JIS

TYPE		Capacity 20 HR (AH)	Reserve Capacity (min)	CCA (EN/SAE) (A)	Max.Overall Dimension (mm)			Base Hold Down	Terminal Type	Terminal Layout
Box	Part Number				Length	Width	Total Height			
D31	EFB.SMF90D31L	90	158	800	306	175	225	B4	A1	0
D31	EFB.SMF90D31R	90	158	800	306	175	225	B4	A1	1
D31	EFB.SMF100D31L	100	179	900	306	175	225	B4	A1	0
D31	EFB.SMF100D31R	100	179	900	306	175	225	B4	A1	1



2x

ADVANCED EFB 

Battery Terminals

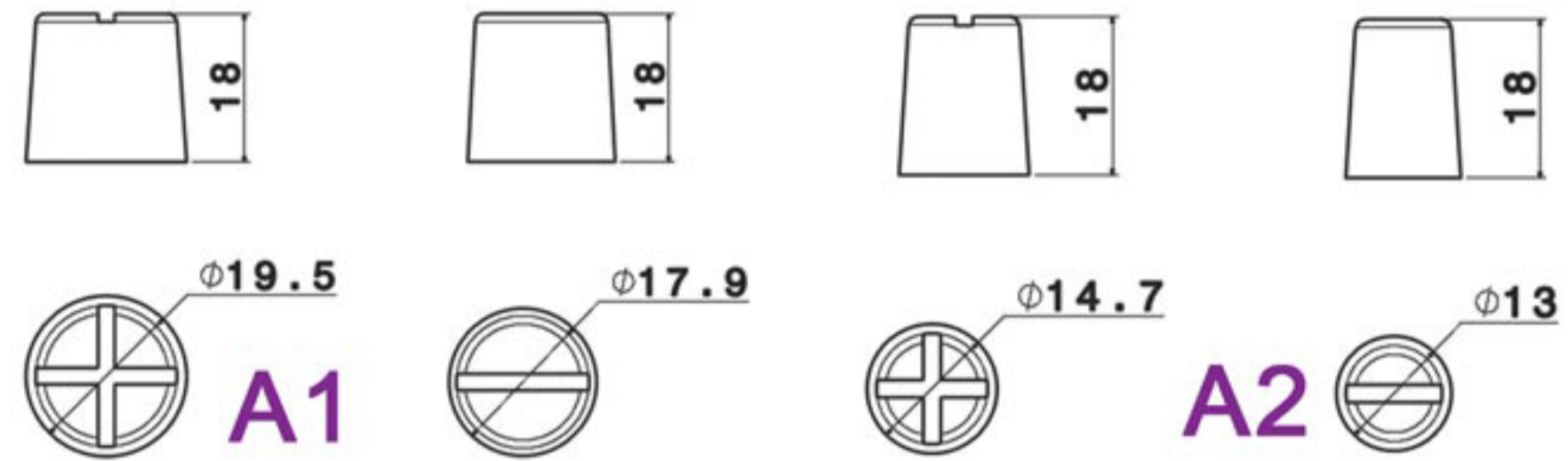

LAYOUTS, HOLD DOWN AND TERMINALS

Battery Terminals Layout

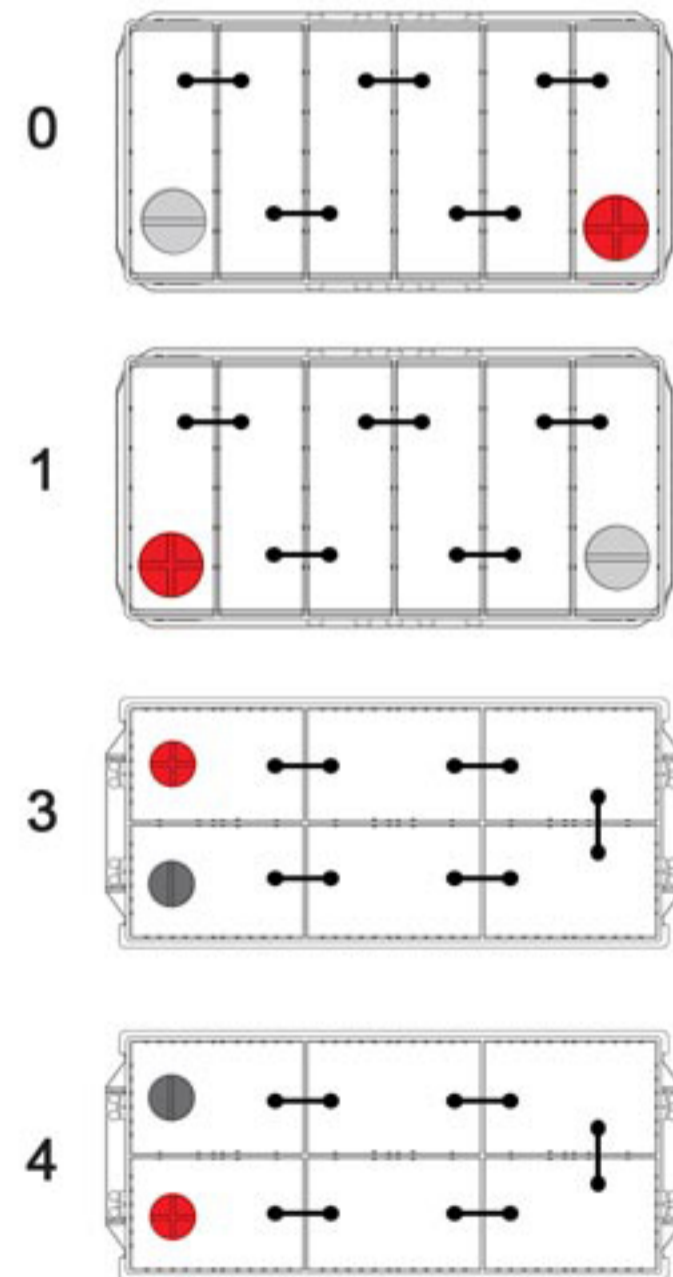

Battery Base Hold Down

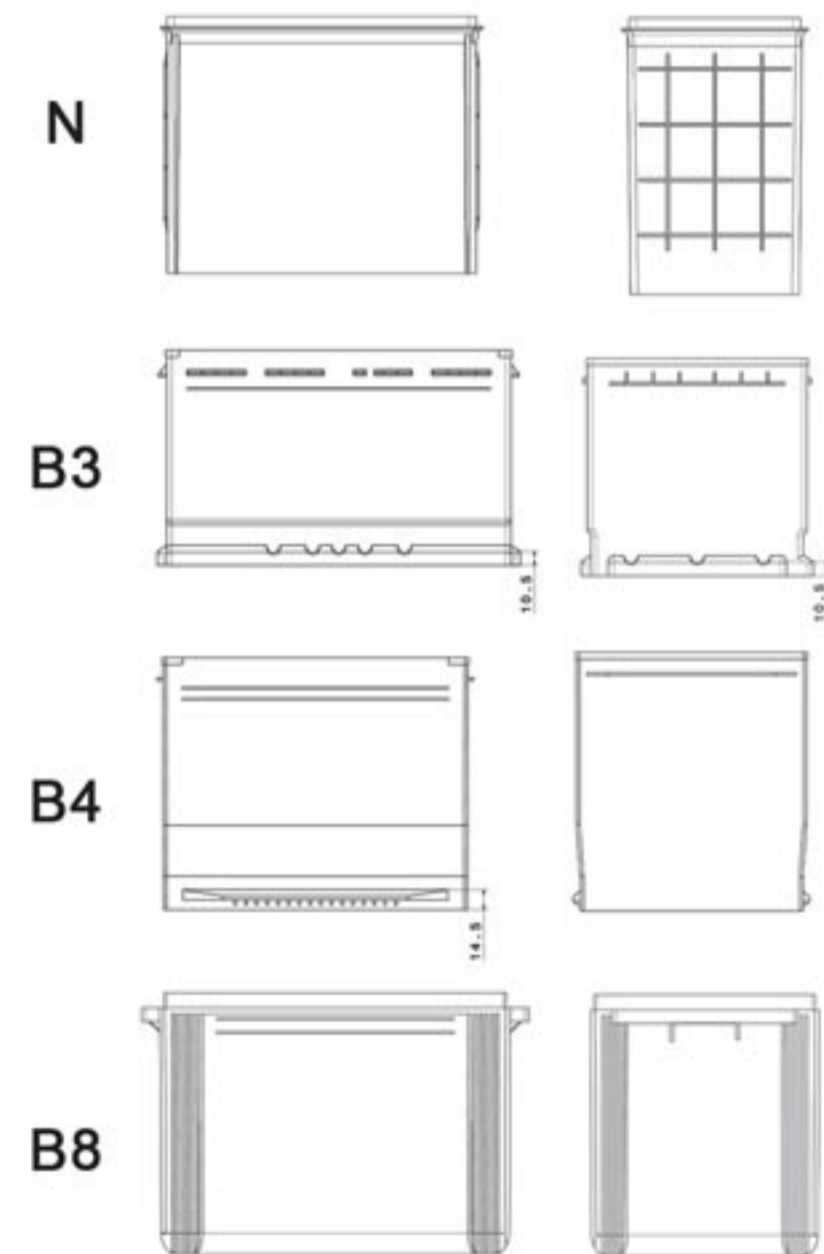





www.sepahanbattery.com

P.O.Box : 8 1 6 5 5 - 1 3 1 6

Office : (+98 31) 35053395

Fax : (+9831) 37608030

Email : info@sepahanbattery.com

@ S E P A H A N B A T T E R Y

